

ARC50



ACOUSTIC & ELECTRICAL SPECIFICATIONS:

- Nominal Impedance 8 ohms
- Max Amp Power 140 watts
- Frequency Response 36 Hz - 23 kHz (± 3 dB)
- Sensitivity 91 dB (1 watt @ 1 meter)
- Crossover Frequency 2300 Hz

SYSTEM COMPONENTS:

- Cabinet ARC50 (Not for Sale)
- Grille 308558-002
- Low Frequency Transducer 8" High Polymer Laminate (330053-001)
- DC Resistance 5.5 ohms $\pm 10\%$
- High Frequency Transducer 1" (25mm) Titanium Dome (330050-001)
- DC Resistance 3.7 ohms $\pm 10\%$
- Crossover Network 330132-001

AURAL SWEEP TEST SPECIFICATIONS:

- System Aural Sweep Test 6.0V Input 20 Hz to 23 kHz
- L.F. Aural Sweep Test 6.0V Input 30 Hz to 3 kHz
- H.F. Aural Sweep Test 3.0V Input 2 kHz to 23 kHz

PHYSICAL SPECIFICATIONS:

- Enclosure dimensions: 23 $\frac{1}{8}$ x 12 $\frac{1}{8}$ x 11 $\frac{7}{16}$ " (H x W x D)
587 x 308 x 291mm
- Weight 59 lbs. (26.7kg) Sold in Pairs

WARRANTY:

- Refer to Warranty Statement packed with each product.

PACKAGING

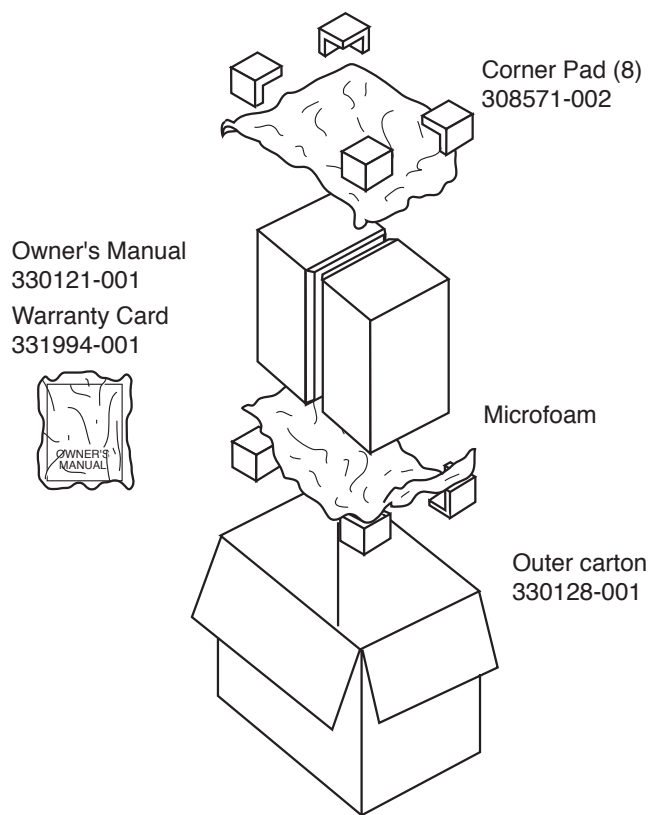

WIRING DIAGRAM

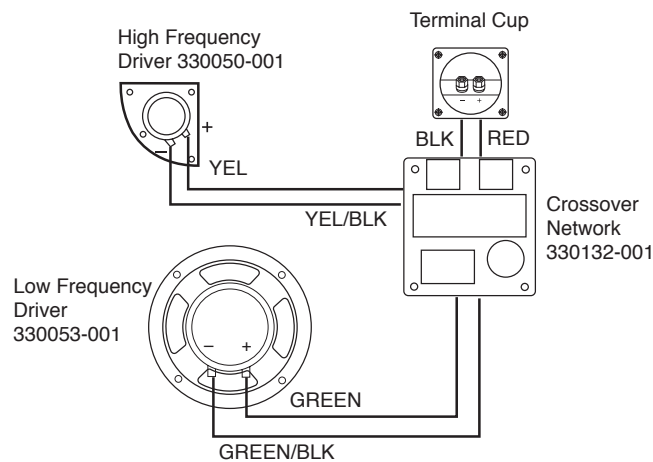

ARC50 SCHEMATIC

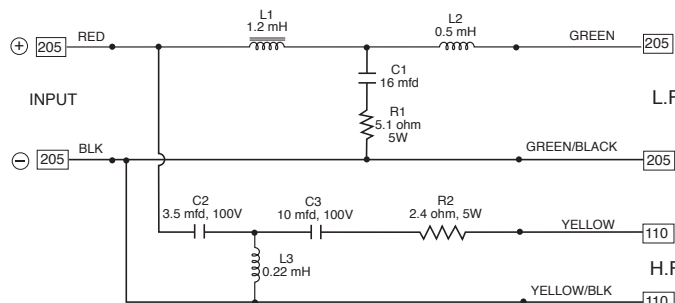

ARC50

ARC50



EXPLODED VIEW

