

ARC10

SPECIFICATIONS

ACOUSTIC & ELECTRICAL SPECIFICATIONS:

- Nominal Impedance: 8 ohm
- Max Amp Power: 50W
- Frequency Response: 75 Hz – 20 kHz (-6 dB)
- Sensitivity: 86 dB SPL, 1 Watt @ 1 Meter
- Crossover Frequency: 2.2 kHz

SYSTEM COMPONENTS:

- Cabinet: ARC10 (Not For Sale)
- Grille: (Not For Sale)
- Low Frequency Transducer: 5 in. (130mm) 10-601-S
DC Resistance: 3.9 ohm ±5%
- High Frequency Transducer: 2 in. (51mm) Paper Cone 72273
DC Resistance: 6.4 ohm ±10%

SYSTEM COMPONENTS: *(cont'd)*

- Crossover Network: ARC10 (10-603-S)

AURAL SWEEP TEST SPECIFICATIONS:

- A. System Aural Sweep Test: 6.0V Input, 20 Hz to 20 kHz
- B. L.F. Aural Sweep Test: 6.0V Input, 20 Hz to 4 kHz
- C. H.F. Aural Sweep Test: 3.0V Input, 4 kHz to 20 kHz

PHYSICAL SPECIFICATIONS:

- Enclosure Dimensions: 10.75 x 6.5 x 7.25 in. D (273mm x 165mm x 184mm D)

SHIPPING WEIGHT:

16 lbs. (7.2 kg.) (In Pairs)

WARRANTY INFORMATION:

- Refer to the Warranty Statement packed with each product.

PACKAGE

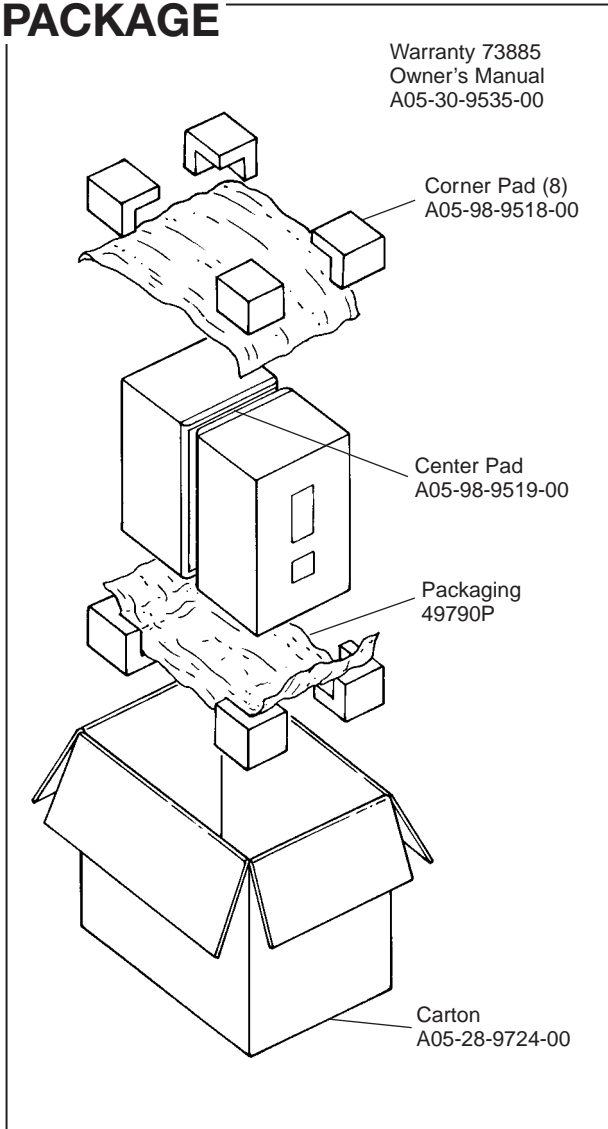

WIRING DIAGRAM

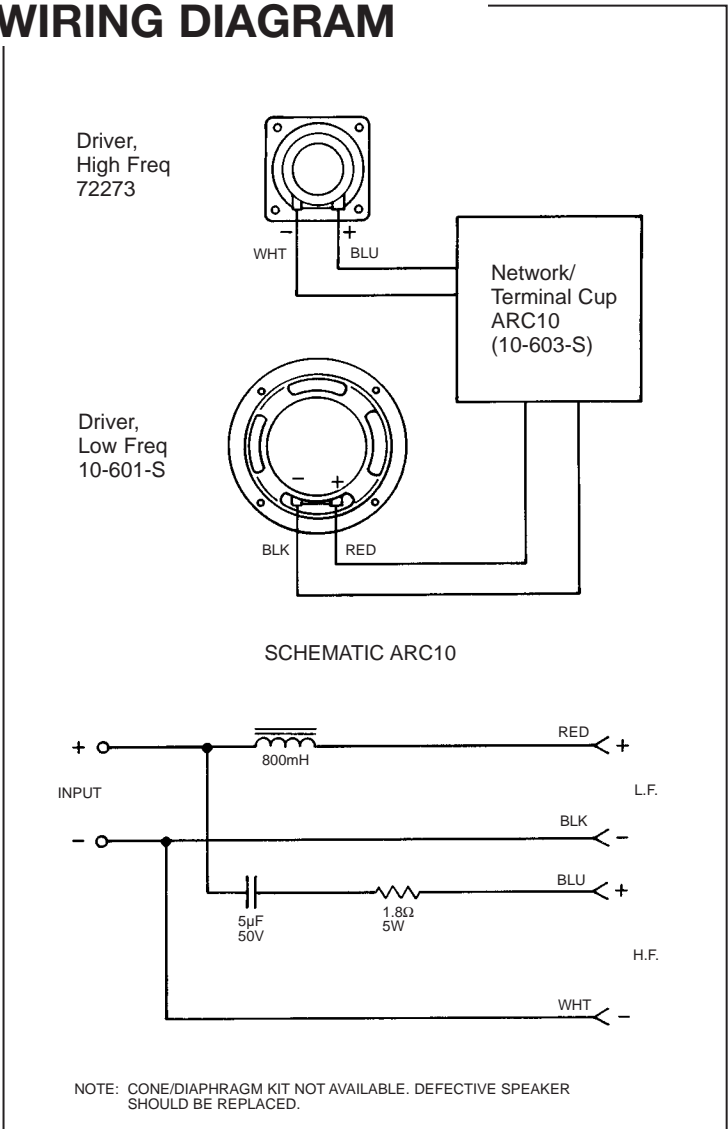

ARC10

ARC10

COMPONENT EXPLODED VIEW

