

Technical Manual

4318



ACOUSTIC & ELECTRICAL SPECIFICATIONS:

- Nominal Impedance 6 ohms
- Max Amp Power 150 watts*
- Frequency Response 50Hz – 40kHz (-6dB)
- Sensitivity 92dB (2.83V @ 1 meter)
- Crossover Frequencies 850Hz, 4700Hz

SYSTEM COMPONENTS:

- Cabinet 4318 (not for sale)
- Grille 352997-001
- Low-Frequency Transducer 12" (305mm) 2213Nd
352974-001
DC Resistance 4.6 ohms ±10%
- Mid-Frequency Transducer 4" (101mm) 105H
352977-001
DC Resistance 4.5 ohms ±10%
- High-Frequency Transducer 1" (25mm) 054Ti-1
353016-001
DC Resistance 3.5 ohms ±10%
- Crossover Network – LF 352999-002
HF w/L-Pad 352999-001

AURAL SWEEP TEST SPECIFICATIONS:

- System Aural Sweep Test 6.0V Input 50Hz to 20kHz
- L.F. Aural Sweep Test 5.0V Input 50Hz to 1kHz
- M.F. Aural Sweep Test 4.0V Input 2kHz to 5kHz
- H.F. Aural Sweep Test 2.83V Input 4kHz to 20kHz

PHYSICAL SPECIFICATIONS:

- Enclosure dimensions 23-1/2" x 14-1/4" x 11-3/8"
(H x W x D) (597mm x 362mm x 289mm)
- Weight 43 lb (19.5kg) each

WARRANTY:

- Refer to Warranty Statement packed with each product.

* The maximum recommended amplifier power rating will ensure proper system headroom to allow for occasional peaks. We do not recommend sustained operation at these maximum power levels.

PACKAGING

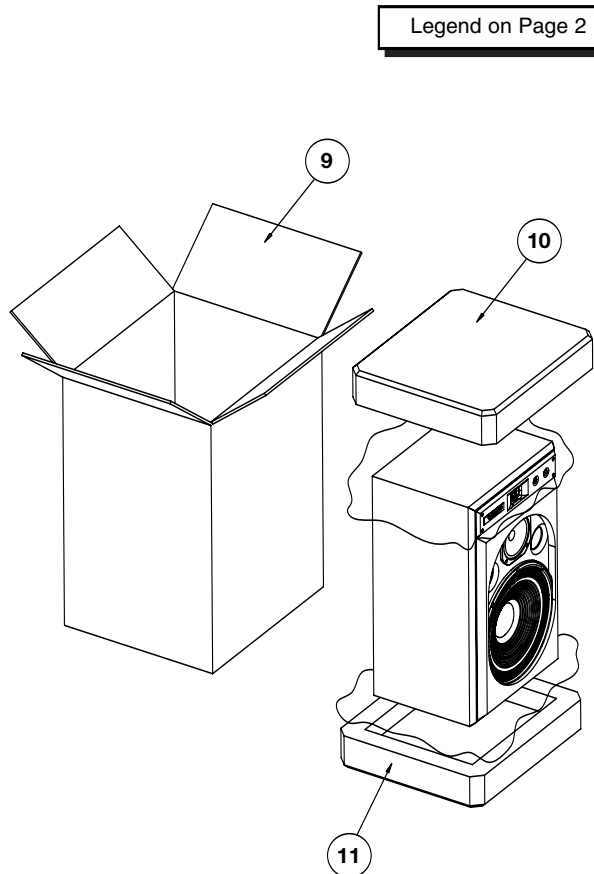

4318 WIRING DIAGRAM

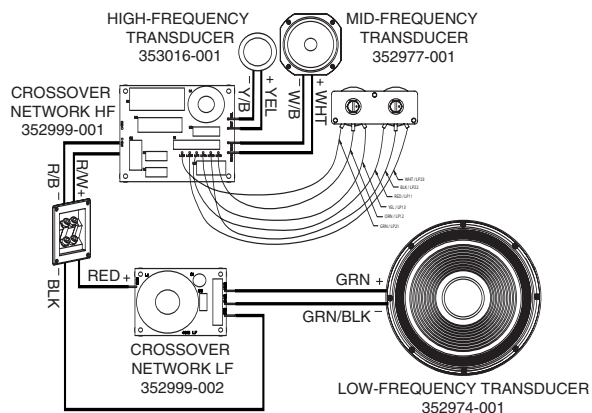

4318 SCHEMATIC

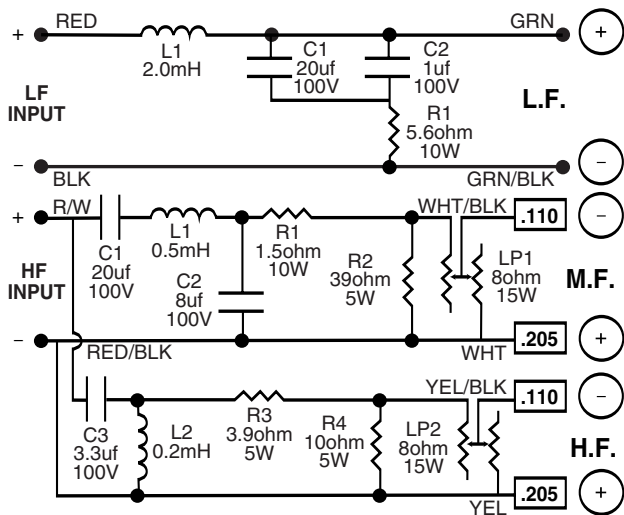

4318

Technical Manual

4318



EXPLODED VIEW

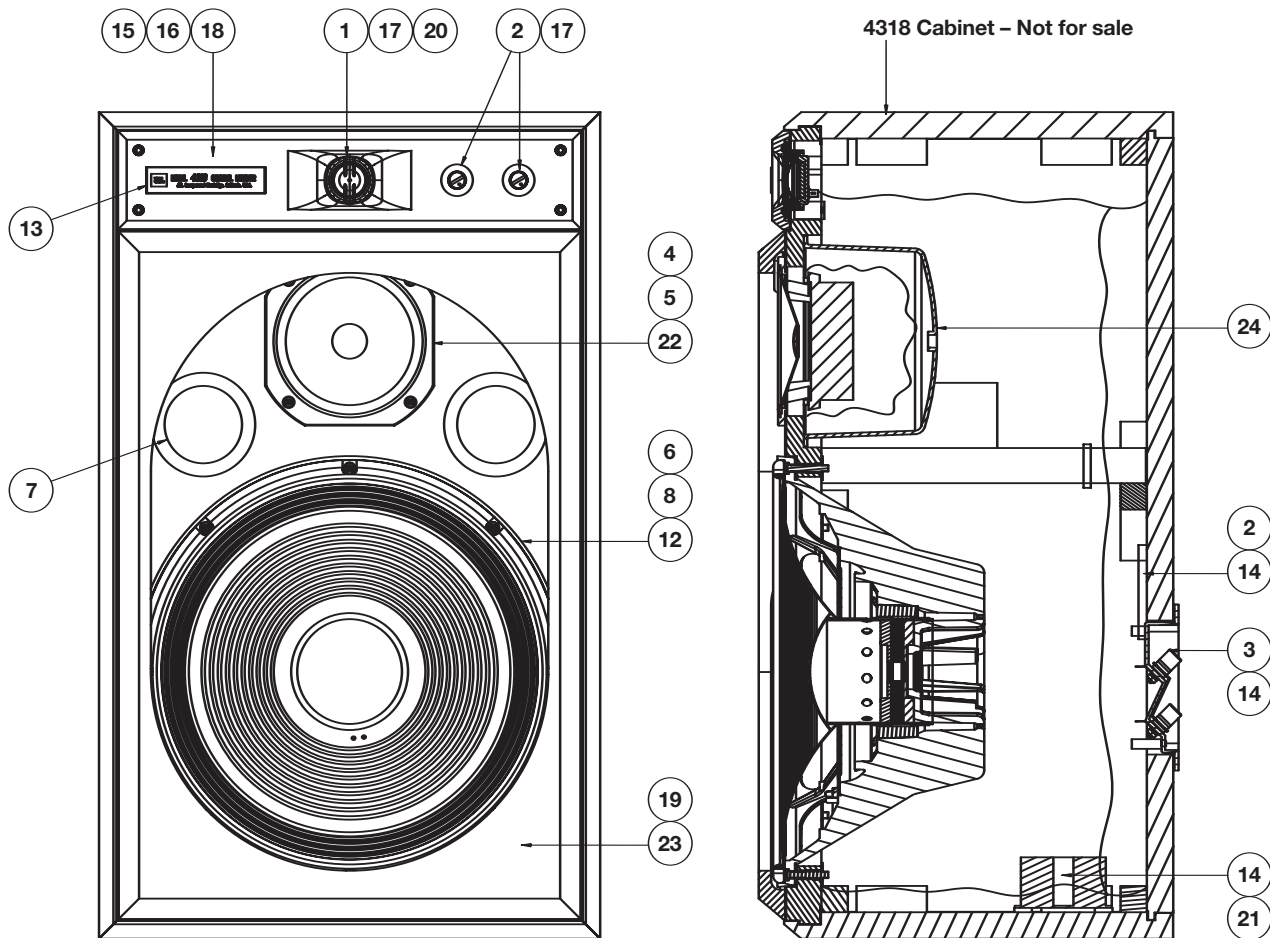

ITEM NO.	DESCRIPTION	QTY.	PART NO.	ITEM NO.	DESCRIPTION	QTY.	PART NO.
1.	Tweeter 054Ti-1	1	353016-001	14.	Screw (network) 6 X 3/4" OV, PH, PTCL, BLK ZINC	12	882-51110-12
2.	Crossover Network, HF W/L-Pad	1	352999-001	15.	Bezel, Finished	1	353015-002
3.	Terminal Cup	1	351441-001	16.	Gasket, Bezel	1	353091-001
4.	Midrange 105H	1	352977-001	17.	Screw (L-pad Bezel/tweeter bezel) 6-32 X 3/8" PAN, PH, CLR ZINC, LCS	5	802-41000-06
5.	Screw (midrange) 8 X 3/4" PAN PH, CLR ZINC, LCS	4	883-41100-12	18.	Screw (bezel/cab) 8-32 X 1", FIL, PH, BLK ZINC LCS	4	803-01010-16
6.	12" Woofer 2213Nd	1	352974-001	19.	Grille Cup, BLK	4	333249-001
7.	Port Tube	2	47909-61	20.	Tweeter Gasket	1	353105-001
8.	Woofer Gasket	1	335481-002	21.	Crossover Network LF	1	352999-002
9.	Outer Carton	1	352998-001	22.	Midrange gasket	1	353024-001
10.	Top End Pad	1	47218-02	23.	4318 Grille	1	352997-001
11.	Bottom End Pad	1	47218-01	24.	Midrange Cup	1	334072-001
12.	Screw (woofer) 10-32 X 1", FIL, PH, BLK ZINC LCS	8	804-01110-16				
13.	Nameplate	1	353000-001				